



*Ecosys FS-C5016N
Color Laser Printer*

PARTS LIST

Published in June 10, 2003
2D970770
842D9120

Contents

Exterior Covers (01-)	3
Upper Frame Unit (02-)	5
Drive Units (03-)	8
Controller Box (04-)	10
Paper Feed Unit (05-)	12
Fuser Unit (06-)	15
Drum Unit / LED Unit (07-)	18
Developer Unit (08-)	20
Frame MP Assembly (9-)	22
MP Tray (10-)	24
Primary Transfer Unit (11-)	26
Paper Cassette (12-)	28
Accessories (A-)	30
Packing Assemblies (P-)	32

Notes on Ordering

- Parts with + are component parts or sub-assemblies of the assembly appearing above them.
- Parts with ++ are component parts of the assembly marked with + immediately above them.
- SP means service parts that are available for ordering.

1. Exterior Covers (01-)

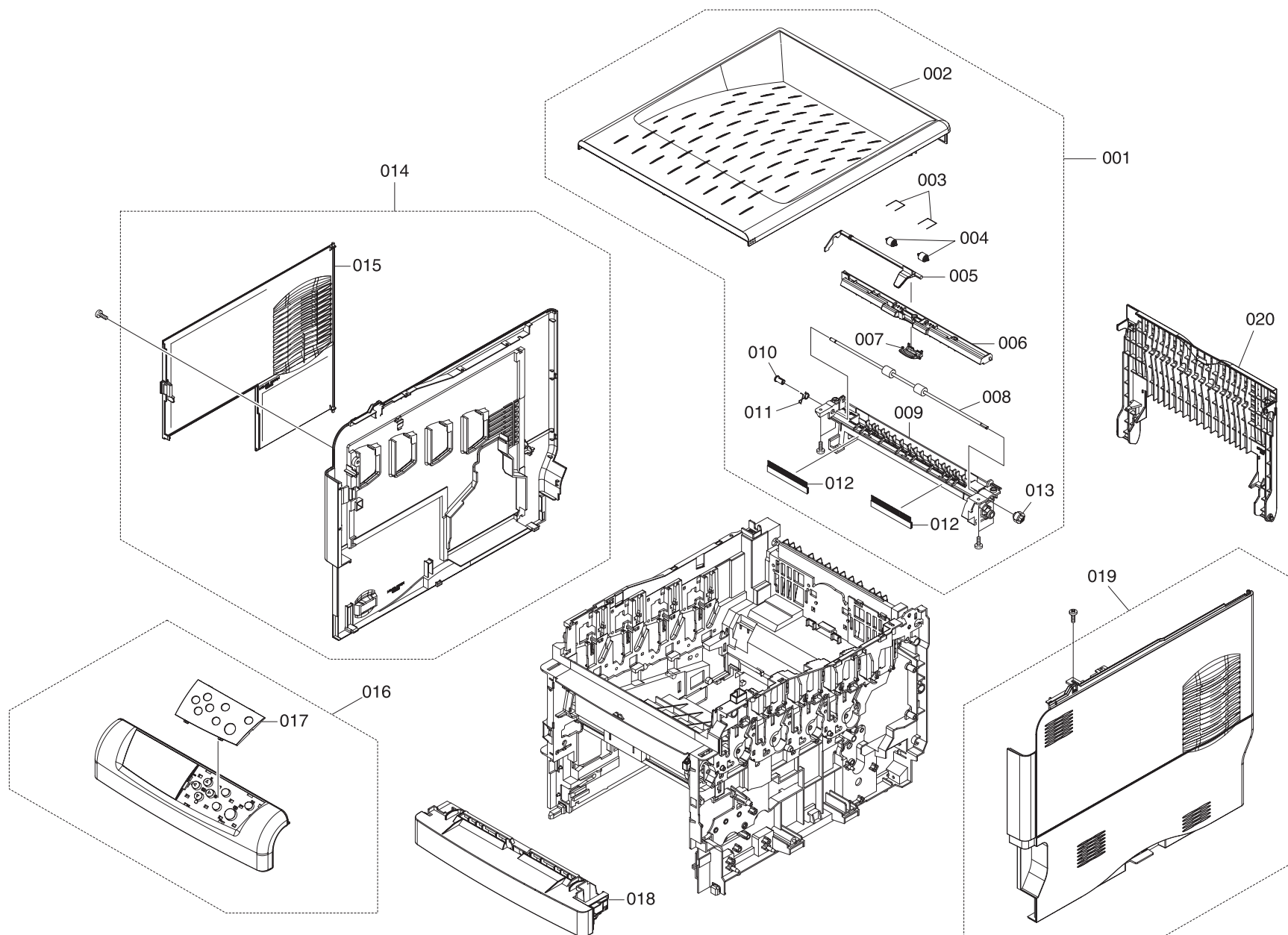

List 1 - Exterior Covers (01-)

Ref. No.	Part Code	Description	Applicable Model	SP	120V	230V	Remarks
01-001	2D969100	COVER TOP ASSY		X	1	1	
01-002	2D904010	COVER TOP		X	1	1	
01-003	+ 5MMW251LD046	SPRING PULLEY		X	2	2	
01-004	+ 5MVM273DB006	ROLLER PINCH		X	2	2	
01-005	+ 5MVX732CB003	ACTUATOR FD		X	1	1	
01-006	+ 5MVX852CH002	FRAME FD		-	1	1	
01-007	+ 2D904170	GUIDE STOCK		X	1	1	
01-008	+ 2D904090	ROLLER FD		X	1	1	
01-009	+ 2D904060	FRAME FD LOW		-	1	1	
01-010	+ 5MVM266DN006	BUSH FD		X	1	1	
01-011	+ 2D902570	SPRING FRAME FD LOW		-	1	1	
01-012	+ 2D904250	DISCHARGER FD		X	2	2	
01-013	+ 5MVG127DN076	GEAR ROLL FD Z18		X	1	1	
01-014	2D969110	COVER LEFT ASSY		X	1	1	
01-015	+ 2D904040	COVER SIDE		X	1	1	
01-016	2D968530	KEY BOARD ASSY	Excl. KMFR/KMIT	X	1	1	
01-016	2D969250	KEY BOARD ASSY	KMFR only	X	-	1	
01-016	2D969260	KEY BOARD ASSY	KMIT only	X	-	1	
01-017	+ 2D924060	COVER PANEL E	Excl. KMFR/KMIT	X	1	1	
01-017	+ 2D904100	COVER PANEL FRENCH	KMFR only	X	-	1	
01-017	+ 2D904110	COVER OABEL ITALIAN	KMIT only	X	-	1	
01-018	5MVB866CH022	COVER FRONT		X	1	1	
01-019	2D969120	COVER RIGHT ASSY		X	1	1	
01-020	2D904050	COVER REAR		-	1	1	

2. Upper Frame Unit (02-)

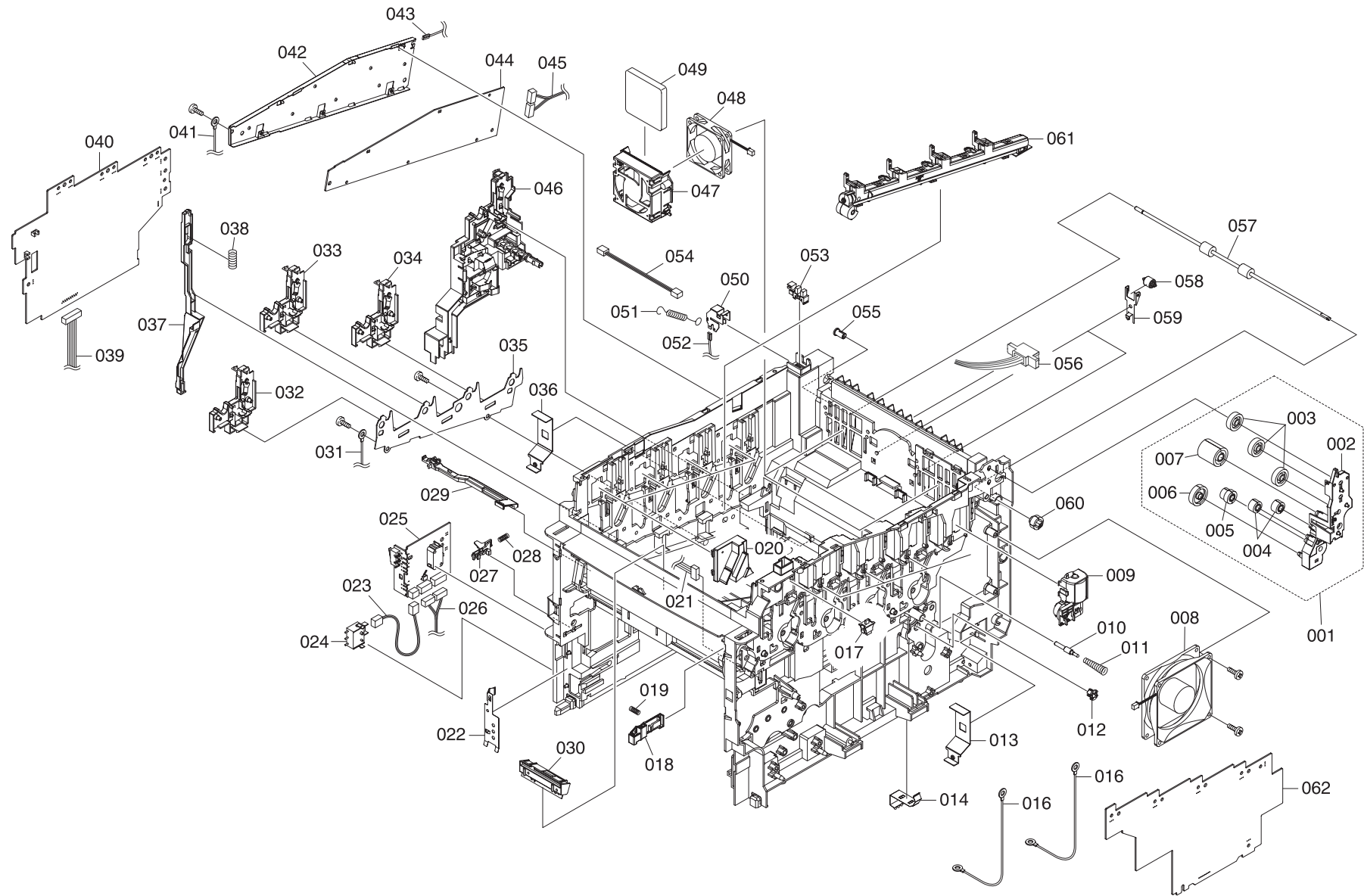

List 2 - Upper Frame Unit (02-)

Ref. No.	Part Code	Description	Applicable Model	SP	120V	230V	Remarks
02-001	2D968590	BRACKET FD GEAR ASSY		X	1	1	
02-002	+ 2D902390	BRACKET FD GEAR		X	1	1	
02-003	+ 5MVG137DN014	GEAR IDLE Z25		X	3	3	
02-004	+ 5MVG127DW004	GEAR IDLE Z16		X	2	2	
02-005	+ 2D902400	GEAR FD Z15-Z18		X	1	1	
02-006	+ 5MVG138DN048	GEAR FD Z29		X	1	1	
02-007	+ 5MVG138DN047	GEAR FD Z28		X	1	1	
02-008	WNAA1030	FAN MOTOR		X	1	1	
02-009	2D968610	TONER MOTOR ASSY		X	4	4	
02-010	5MMT463SN001	PIN CONTACT BIAS		-	1	1	
02-011	2D902580	SPRING CONTACT CLN		-	1	1	
02-012	2D922250	BUSH FRAME		X	1	1	
02-013	2D902380	PLATE EARTH FUSER		-	1	1	
02-014	2D902330	PLATE EARTH HV B		-	1	1	
02-016	2D926340	CONN. CORD ASSY		-	2	2	S02981
02-017	5ESP01000101*01	PUSH SWITCH 01 SN		X	1	1	
02-018	5MVX522DB006	LOCK COVER M/P		-	1	1	
02-019	5MMW261LD051	SP LOCK COVER M/P		-	1	1	
02-020	2D902370	COVER HARNESS		-	4	4	
02-021	2D926260	CONN. CORD ASSY		-	1	1	
02-022	2D902320	PLATE EARTH HV A		-	1	1	
02-023	2D926160	CONN. CORD ASSY		-	1	1	S02861
02-024	5ESP03090001+01	PUSH SWITCH 03 SN		X	1	1	
02-025	2D901540	P.W.B ASSY KP-982		X			SENSOR
02-026	2D926060	CONN. CORD ASSY		-	1	1	S02849
02-027	5MVX322DB023	LEVER EF		-	1	1	
02-028	5MMW222LD002	SPRING LEVER EF		-	1	1	
02-029	2D969860	CLEANER ID ASSY		X	1	1	
02-030	2D968570	SENSOR ID ASSY		X	1	1	
02-031	2D926280	CONN. CORD ASSY		-	1	1	S02975
02-032	2D969810	BRACKET HV DLP K ASSY		X	1	1	
02-033	2D969830	BRACKET HV DLP Y ASSY		X	1	1	
02-034	2D969820	BRACKET HV DLP C ASSY		X	1	1	
02-035	2D902170	PLATE FRAME DRUM		-	1	1	
02-036	2D902380	PLATE EARTH FUSER		-	1	1	
02-037	2D902310	ROD INTERLOCK		-	1	1	
02-038	5MMW451LD001	SPRING INTER LOCK		-	1	1	
02-039	2D926080	CONN. CORD ASSY		-	1	1	S02851
02-040	2D927070	TRANS ASSY		X	1	1	HI VOLTAGE DLP

Ref. No.	Part Code	Description	Applicable Model	SP	120V	230V	Remarks
02-041	2D926290	CONN. CORD ASSY		-	1	1	
02-042	2D902200	PLATE SHIELD PWB		-	1	1	
02-043	2D926310	CONN. CORD ASSY		-	1	1	
02-044	2D901800	P.W.B ASSY KP-1048	LEDRLY	X	1	1	
02-045	2D926230	CONN. CORD ASSY	S02869	-	1	1	
02-046	2D968560	BRACKET HV ASSY		X	1	1	
02-047	2D902540	BRACKET FAN		-	2	2	
02-048	WNAA1050	FAN MOTOR		X	2	2	
02-049	2D902530	OZONE FILTER		X	2	2	
02-050	2D902550	PLATE EARTH FD		-	1	1	
02-051	2D902560	SPRING EARTH FD		-	1	1	
02-052	2D926320	CONN. CORD ASSY	S02979	-	1	1	
02-053	2BZ16530	PT.SENSOR EE-SX1235A		X	1	1	
02-054	2D926240	CONN. CORD ASSY	S02870	-	1	1	
02-055	5MVM266DN006	BUSH FD		X	1	1	
02-056	2D926120	CONN. CORD ASSY	S02856	-	1	1	
02-057	2D902690	ROLLER FD LOW		X	1	1	
02-058	5MVM273DB006	ROLLER PINCH		X	2	2	
02-059	2D902410	BRACKET ROLLER PINCH		-	2	2	
02-060	5MVG127DN076	GEAR ROLL FD Z18		X	1	1	
02-061	2D968520	WASTE TONER ASSY		X	1	1	
02-062	2D927060	TRANS ASSY	HI VOLTAGE MAIN	X	1	1	

3. Drive Units (03-)

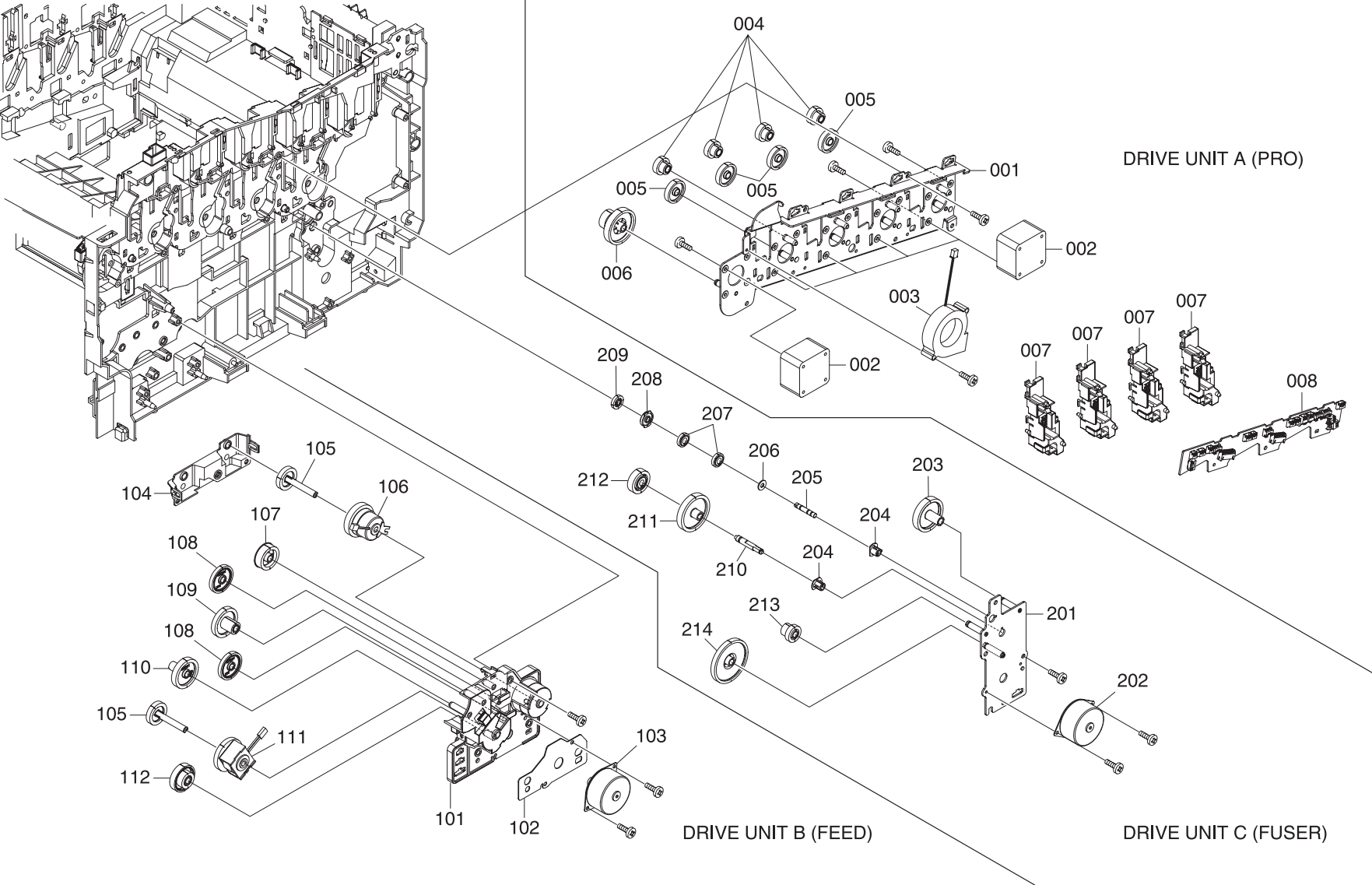

List 3 - Drive Units (03-)

Ref. No.	Part Code	Description	Applicable Model	SP	120V	230V	Remarks
	2D993170	DR-500A DRIVE UNIT	PRO	X	1	1	
03-001	+ 2D922150	PLATE DRIVE MAIN		-	1	1	
03-002	+ WNAA1000	STEPPING MOTOR PRO		X	5	5	
03-003	+ WNAA1040	FAN MOTOR		X	1	1	
03-004	+ 2D922160	GEAR Z21H-Z20H		X	4	4	
03-005	+ 2D922170	GEAR Z45H		X	4	4	
03-006	+ 2D922180	GEAR Z72H-Z22H		X	1	1	
03-007	+ 2D968810	BRACKET HV MAIN ASSY		-	4	4	
03-008	+ 2D901420	P.W.B.ASSY KP-966	ENGRLY	X	1	1	
	2D993180	DR-500B DRIVE UNIT	FEED	X	1	1	
03-101	+ 2D922010	BRACKET DRIVE FEED		-	1	1	
03-102	+ 2D922260	SHEET MOTOR FEED		-	1	1	
03-103	+ WNAA1010	STEPPING MOTOR FEED		X	1	1	
03-104	+ 2D922020	COVER DRIVE FEED		-	1	1	
03-105	+ 2D922080	GEAR CL Z21S		X	2	2	
03-106	+ 2D922270	CLUTCH REGIST		X	1	1	
03-107	+ 2D922050	GEAR Z30S		X	1	1	
03-108	+ 2D922040	GEAR Z35S		X	2	2	
03-109	+ 2D922060	GEAR Z38S-Z14S		X	1	1	
03-110	+ 2D922070	GEAR Z38S		X	1	1	
03-111	+ YY000290	CLUTCH FEED		X	1	1	
03-112	+ 2D922030	GEAR Z56S-Z20S		X	1	1	
	2D993190	DR-500C DRIVE UNIT	FUSER	X	1	1	
03-201	+ 2D922090	PLATE DRIVE FUSER		-	1	1	
03-202	+ WNAA1020	STEPPING MOTOR FUSER		X	1	1	
03-203	+ 2D922130	GEAR Z43S		X	1	1	
03-204	+ 2D922240	BUSH SHAFT CLUTCH		X	2	2	
03-205	+ 2D915250	SHAFT CLUTCH B		-	1	1	
03-206	+ C2890150	POLY WASHER		-	1	1	
03-207	+ 2D969870	GEAR Z22S ASSY		X	2	2	
03-208	+ 2D915200	BUSH DRIVE FUSER		X	1	1	
03-209	+ 2D915210	GEAR DRIVE FUSER Z22		X	1	1	
03-210	+ 2D922220	SHAFT CLUTCH		-	1	1	
03-211	+ 2D922110	GEAR Z48S		X	1	1	
03-212	+ 2D969180	GEAR Z29S ASSY		X	1	1	
03-213	+ 2D922140	GEAR Z14-Z20		X	1	1	
03-214	+ 2D922100	GEAR Z93S-Z24S		X	1	1	

4. Controller Box (04-)

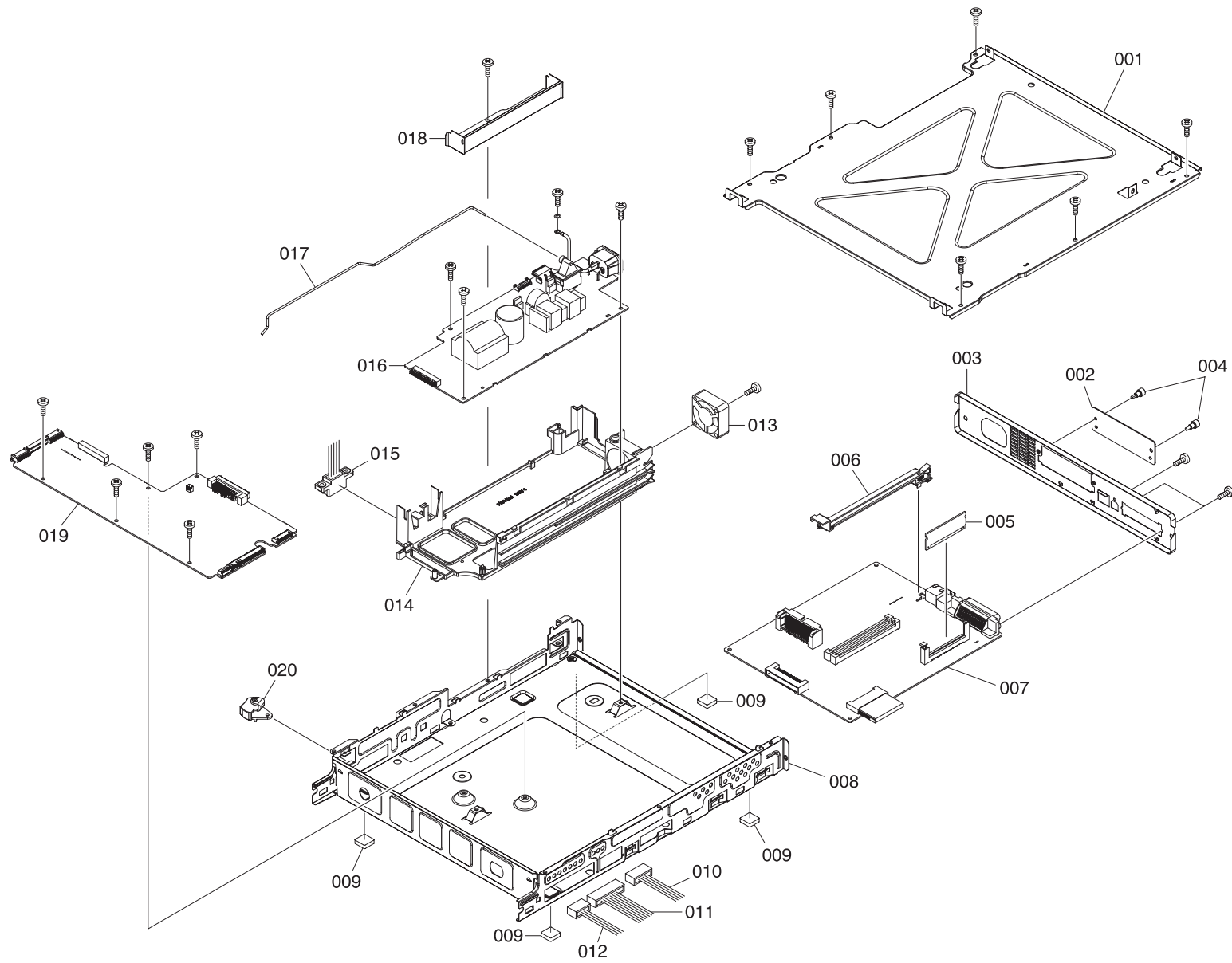

List 4 - Controller Box

Ref. No.	Part Code	Description	Applicable Model	SP	120V	230V	Remarks
04-001	2D903020	LID CONTROLLER		-	1	1	
04-002	5MMS636SD009	PLATE OPTION		-	1	1	
04-003	2D903030	PANEL REAR		-	1	1	
04-004	5MMT263SN012	SCREW OP		X	2	2	
04-005	2D901620	P.W.B.ASSY KP-893	FLASH DIMM	X	1	1	
04-006	2D903070	RAIL OPTION		-	1	1	
04-007	2D901200	P.W.B.ASSY KP-957	MAIN	X	1	1	
04-008	2D903010	BOX CONTROLLER		-	1	1	
04-009	5MVX221RB014	FOOT		X	4	4	
04-010	2D926030	CONN. CORD ASSY	S02846	-	1	1	
04-011	2D926020	CONN. CORD ASSY	S02845	-	1	1	
04-012	2D926070	CONN. CORD ASSY	S02850	-	1	1	
04-013	WNA00580	FAN MOTOR		X	1	1	
04-014	2D903050	CASE PWB POWER		-	1	1	
04-015	2D926090	CONN. CORD ASSY	S02852	X	1	1	
04-016	2D928610	SWITCHING REGULATOR		X	-	1	
04-016	2D928600	SWITCHING REGULATOR		X	1	-	
04-017	2D903060	ROD SW POWER		-	1	1	
04-018	2D903040	BRACKET BOX		-	1	1	
04-019	2D901720	P.W.B.ASSY KP-1054	ENGINE	Incl. KMTW	X	-	1
04-019	2D901730	P.W.B.ASSY KP-1054	ENGINE	Excl. KMTW	X	1	-
04-020	5MVX433SH002	LEVER SW		-	1	1	

5. Paper Feed Unit (05-)

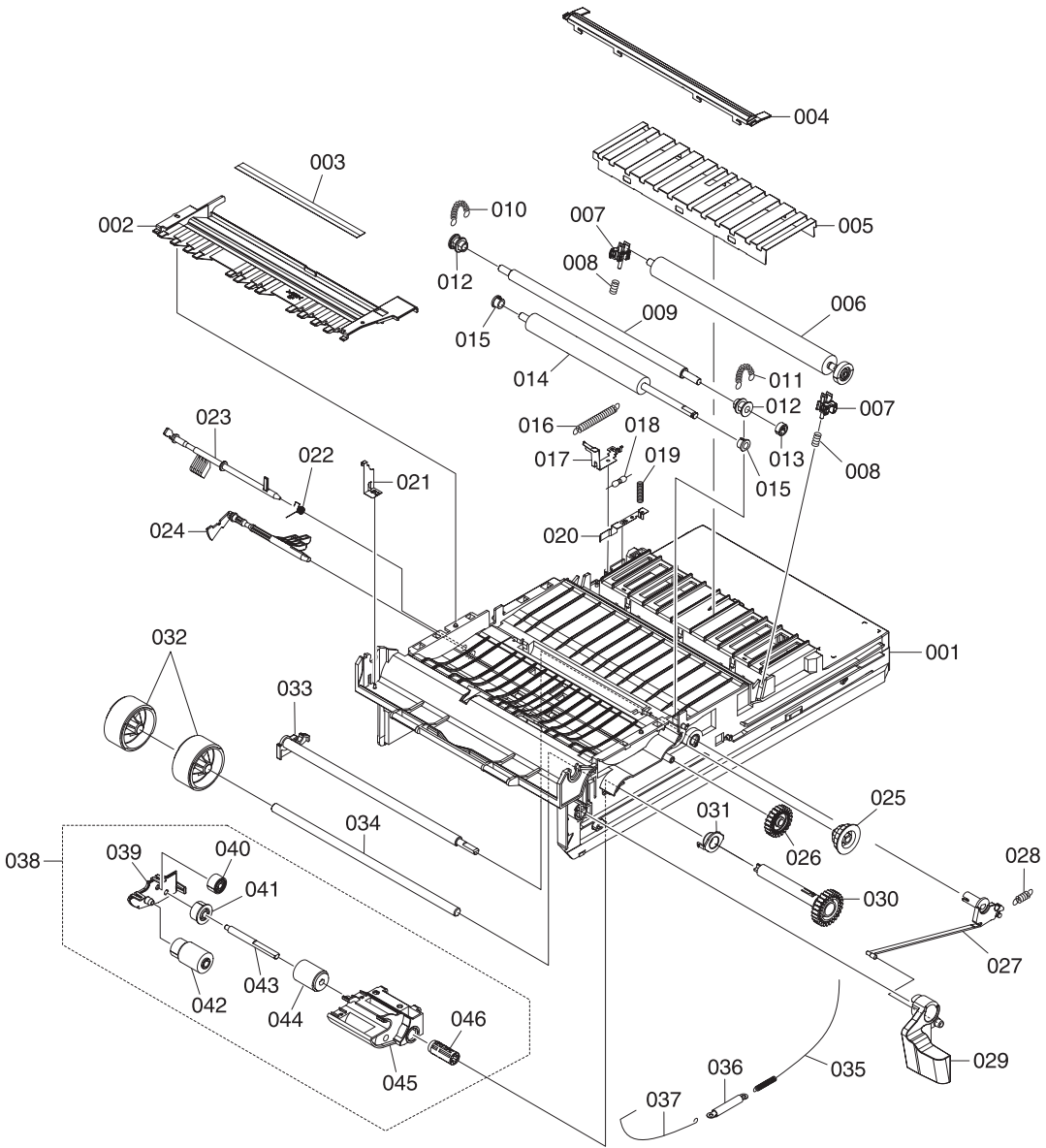

List 5 - Paper Feed Unit (05-)

Ref. No.	Part Code	Description	Applicable Model	SP	120V	230V	Remarks
	2D993140	FE-500 FEED TRANS UNIT		X	1	1	
05-001	+ 2D916050	BASE FEED		-	1	1	
05-002	+ 2D916070	GUIDE PAPER		-	1	1	
05-003	+ 2D916150	SHEET REGIST		X	1	1	
05-004	+ 2D916080	PAPER CHUTE		X	1	1	
05-005	+ 2D968830	DISCHARGER ASSY		-	1	1	
05-006	+ 2D968840	ROLLER TRANSFER ASSY		X	1	1	
05-007	+ 5MVX322DB019	BUSH TRANSFER		X	2	2	
05-008	+ 2D916060	SPRING TRANS		-	2	2	
05-009	+ 2D916170	ROLLER REGIST UP		X	1	1	
05-010	+ 2D916250	SPRING REGIST L		-	1	1	
05-011	+ 5MMW341LD008	SPRING REGIST R		-	1	1	
05-012	+ 5MVM221DB002	BUSH REGIST		X	2	2	
05-013	+ 5MVG126DN015	GEAR REGIST Z19S		X	1	1	
05-014	+ 2D916180	ROLLER REGIST LOW		X	1	1	
05-015	+ 5MVM176DN019	BUSH POM A		X	2	2	
05-016	+ 2D916130	SPRING EARTH B		-	1	1	
05-017	+ 2D916110	PLATE EARTH TC		-	1	1	
05-018	+ RHOA0040	M.GLAZE R. 100M 1W		-	1	1	
05-019	+ 5MMW241SX005	SPRING TRANS R		-	1	1	
05-020	+ 2D916210	PLATE EARTH FEED		-	1	1	
05-021	+ 2D916140	PLATE EARTH MP		-	1	1	
05-022	+ 2D916260	SPRING ACTUATOR REG		-	1	1	
05-023	+ 5MVX742SB008	SENSOR DOC		X	1	1	
05-024	+ 5MVX663SB013	ACTUATOR PAPER		X	1	1	
05-025	+ 5MVG148DN060	GEAR REG Z22S-Z32S		X	1	1	
05-026	+ 2D916220	GEAR IDLE Z23S		X	1	1	
05-027	+ 2D916090	HOOK RELEASE		-	1	1	
05-028	+ 5MMW251SD002	SPRING LOCK R		-	1	1	
05-029	+ 5MVX666SH005	LEVER LOCK		-	1	1	
05-030	+ 2D916230	GEAR JOINT Z26S		X	1	1	
05-031	+ 5MVM222XN001	BUSH FEED		X	1	1	
05-032	+ 5AAVROLL+049	ROLLER GUIDE ASSY		X	2	2	
05-033	+ 5MVX843CB004	SHAFT RELEASE		-	1	1	
05-034	+ 5MMT860SN002	SHAFT ROLL GUIDE		-	1	1	
05-035	+ 2D916270	SPRING EARTH C		-	1	1	
05-036	+ 2D926390	CONN. CORD ASSY		-	1	1	
05-037	+ 2D916280	WIRE EARTH M/P		-	1	1	

Ref. No.	Part Code	Description	Applicable Model	SP	120V	230V	Remarks
05-038	+ 5AAYA37E++35	HOLDER FEED ASSY		X	1	1	
05-039	++ 5MVX642DH001	COVER BKT FEED		-	1	1	
05-040	++ 5MVG137DN036	GEAR FEED IDLE Z29S		-	1	1	
05-041	++ 5AAVGEAR+037	GEAR PICKUP		X	1	1	
05-042	++ 5AAVROLL+047	ROLLER FEED ASSY		X	1	1	
05-043	++ 5MMT664SN002	SHAFT PICKUP		-	1	1	
05-044	++ 5AAVROLL+048	ROLLER PICKUP ASSY		X	1	1	
05-045	++ 5MVX664SH004	BRACKET FEED		-	1	1	
05-046	++ 5MVX376DN001	HOLDER RELEASE		X	1	1	

6. Fuser Unit (06-)

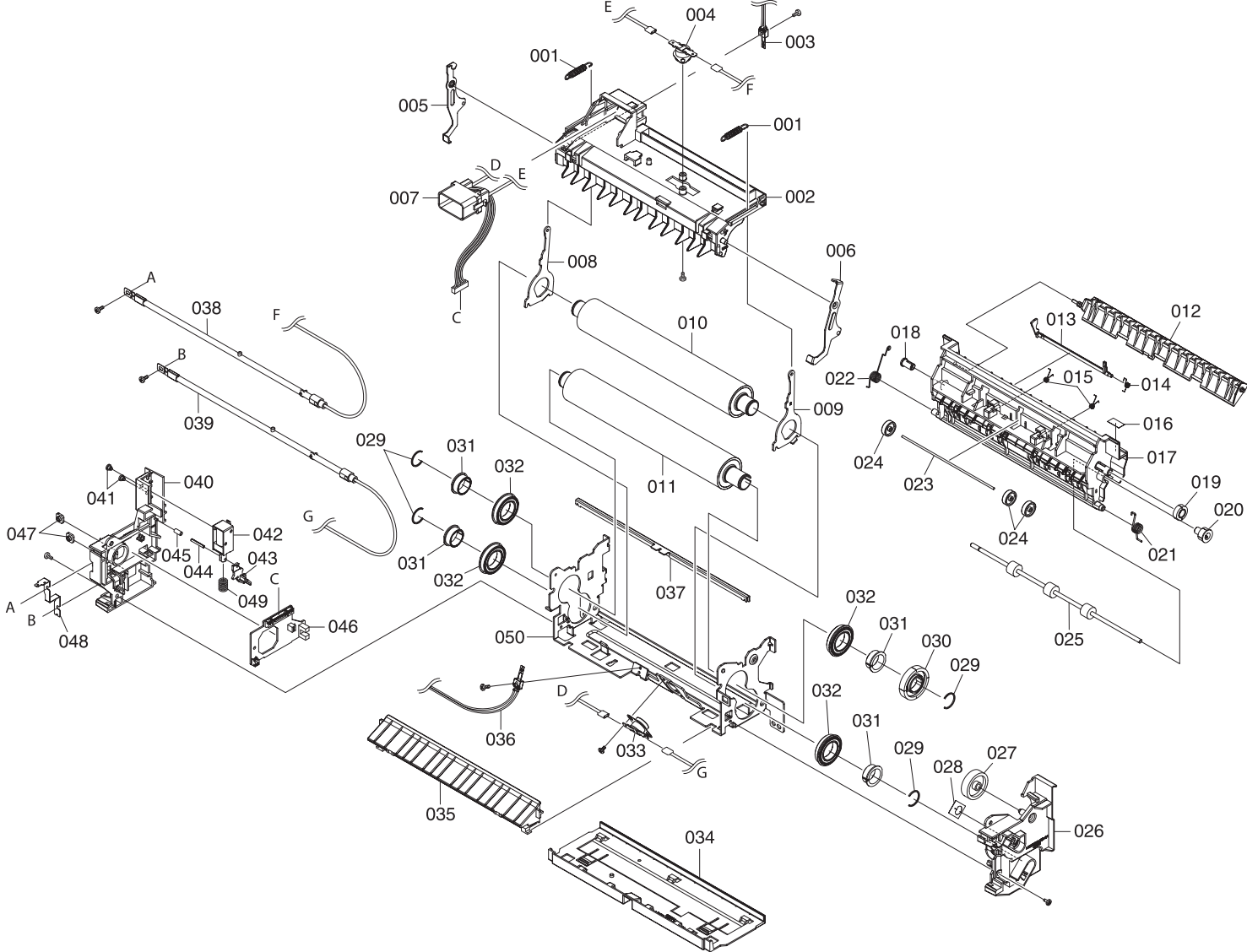

List 6 - Fuser Unit (06-)

Ref. No.	Part Code	Description	Applicable Model	SP	120V	230V	Remarks	Remarks	Remarks
	2D993150	FK-500(E) FUSER UNIT		X	-	1			
	2D993220	FK-500(U) FUSER UNIT		X	1	-			
06-001	+ 2D920250	SPRING PRESS		-	2	2			
06-002	+ 2D920320	FRAME FUSER UP		-	1	1			
06-003	+ 2D927090	THERMISTOR ASSY		X	1	1			
06-004	+ YF0A1530	THERMOSTAT 250V150C		X	1	1			
06-005	+ 2D920190	PLATE RELEASE L		-	1	1			
06-006	+ 2D920200	PLATE RELEASE R		-	1	1			
06-007	+ 2D926130	CONN. CORD ASSY	S02857	-	-	1			
06-007	+ 2D926140	CONN. CORD ASSY		-	1	-			
06-008	+ 2D920170	PLATE PRESS L		-	1	1			
06-009	+ 2D920180	PLATE PRESS R		-	1	1			
06-010	+ 2D920060	ROLLER FIX UP		X	1	1			
06-011	+ 2D920070	ROLLER FIX LOW		X	1	1			
06-012	+ 2D920140	GUIDE CHANGE		-	1	1			
06-013	+ 2D920150	ACTUATOR FUSER		X	1	1			
06-014	+ 2D920280	SPRING ACTUATOR		-	1	1			
06-015	+ 2D920300	SPRING PULLEY EXIT		-	2	2			
06-016	+ 2D920390	LABEL EXIT		-	1	1			
06-017	+ 2D920080	GUIDE EXIT		-	1	1			
06-018	+ 5MVM266DN006	BUSH FD		X	1	1			
06-019	+ 5MVG127DN047	GEAR IDLE Z18		X	1	1			
06-020	+ 2D920040	GEAR EXIT Z15S		X	1	1			
06-021	+ 2D920270	SPRING EXIT R		-	1	1			
06-022	+ 2D920260	SPRING EXIT L		-	1	1			
06-023	+ 5MMT722SZ001	SHAFT EXIT		-	1	1			
06-024	+ 5MVM176DB018	PULLEY EXIT		X	3	3			
06-025	+ 2D920340	ROLLER EXIT		X	1	1			
06-026	+ 2D920120	COVER FUSER R		-	1	1			
06-027	+ 5MVG148XN005	GEAR JOINT Z36		X	1	1			
06-028	+ 2D920360	SEAL HEATER R		-	1	1			
06-029	+ 2D920310	RING STOP		-	4	4			
06-030	+ 2D920020	GEAR HEAT Z43S		X	1	1			
06-031	+ 2D920030	BUSH FUSER		X	4	4			
06-032	+ 2D920350	FUSER BEARING		X	4	4			
06-033	+ YF0A1530	THERMOSTAT 250V150C		X	1	1			
06-034	+ 2D920130	COVER FUSER LOW		-	1	1			
06-035	+ 2D920330	GUIDE ENTRANCE LOW		-	1	1			
06-036	+ 2D927090	THERMISTOR ASSY		X	1	1			

Ref. No.	Part Code	Description	Applicable Model	SP	120V	230V	Remarks	Remarks	Remarks
06-037	+ 2D920210	PLATE STAY		-	1	1			
06-038	+ WP0A0510	LAMP HEATER UP 240V		X	-	1			
06-038	+ WP0A0530	LAMP HEATER UP 120V		X	1	-			
06-039	+ WP0A0520	LAMP HEATER LOW 240V		X	-	1			
06-039	+ WP0A0540	LAMP HEATER LOW 120V		X	1	-			
06-040	+ 2D920110	COVER FUSER L		-	1	1			
06-041	+ 5MMT143SZ014	STUD SCREW M3		-	2	2			
06-042	+ WSA0170	SOLENOID		X	1	1			
06-043	+ 2D920010	ACTUATOR SOL		-	1	1			
06-044	+ 5MBP2518WXSP	SPRING PIN		-	1	1			
06-045	+ 5MVM111RB002	RUBBER PIN		-	1	1			
06-046	+ 2D901460	P.W.B.ASSY KP-970	FUSER	-	1	1			
06-047	+ 5MMS111SL002	NUT FUSER A		-	2	2			
06-048	+ 2D920220	PLATE HEATER L		-	1	1			
06-049	+ 5MMW261LJ032	SPRING SOL		-	1	1			
06-050	+ 2D920050	FRAME FUSER		-	1	1			

7. Drum Unit / LED Unit (07-)

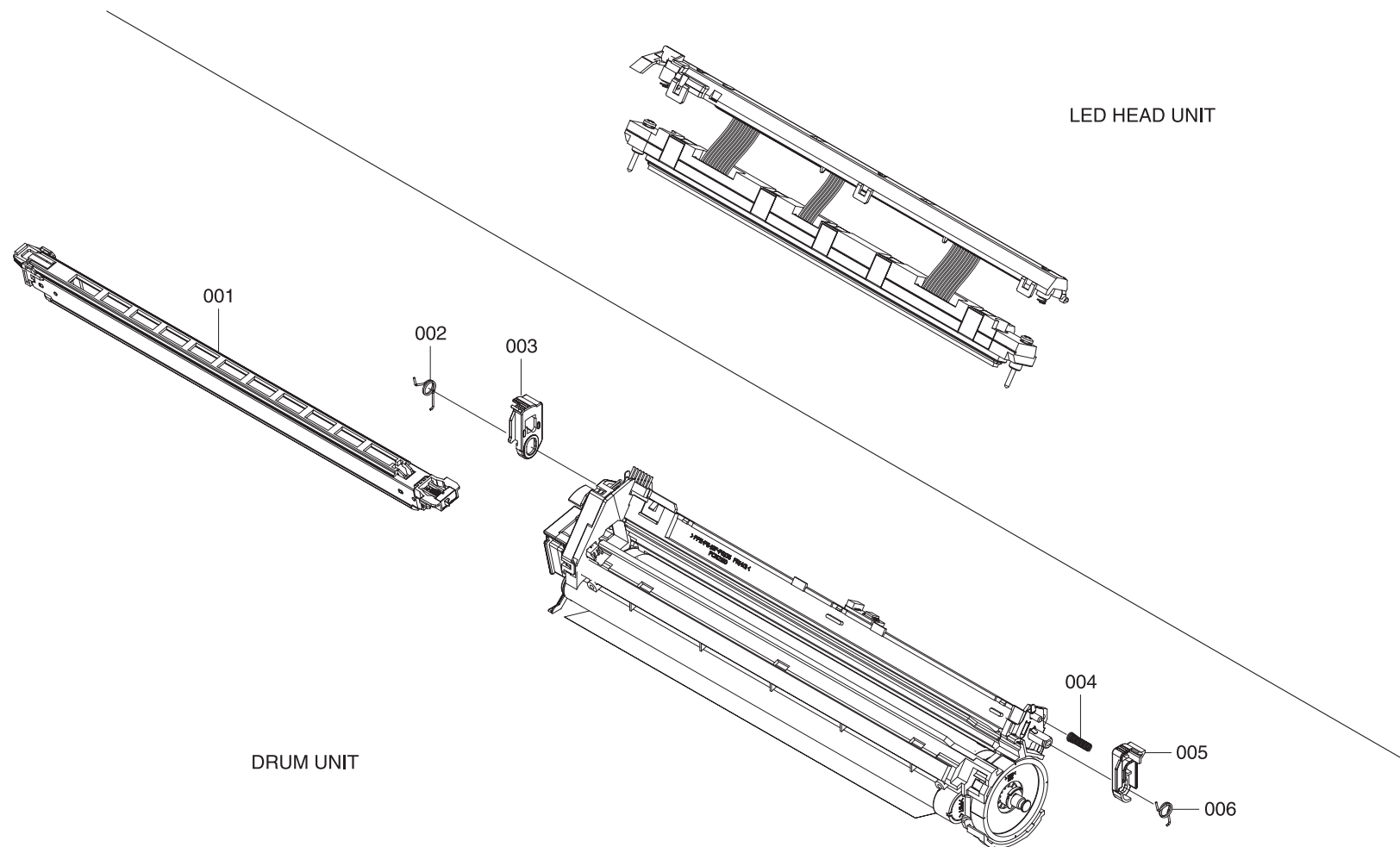

List 7 - Drum Unit / LED Unit (07-)

Ref. No.	Part Code	Description	Applicable Model	SP	120V	230V	Remarks
	2D993200	LK-500 LED HEAD UNIT		X	4	4	
	2D993040	DK-500 DRUM UNIT		X	1	1	
07-001	+ 2D993160	MC-500 MCH ASSY		X	1	1	
07-002	+ 2D908360	SPRING LOCK L		-	1	1	
07-003	+ 2D908340	LEVER DRUM L		-	1	1	
07-004	+ 2D908380	SPRING EARTH		-	1	1	
07-005	+ 2D908350	LEVER DRUM R		-	1	1	
07-006	+ 2D908370	SPRING LOCK R		-	1	1	

8. Developer Unit (08-)

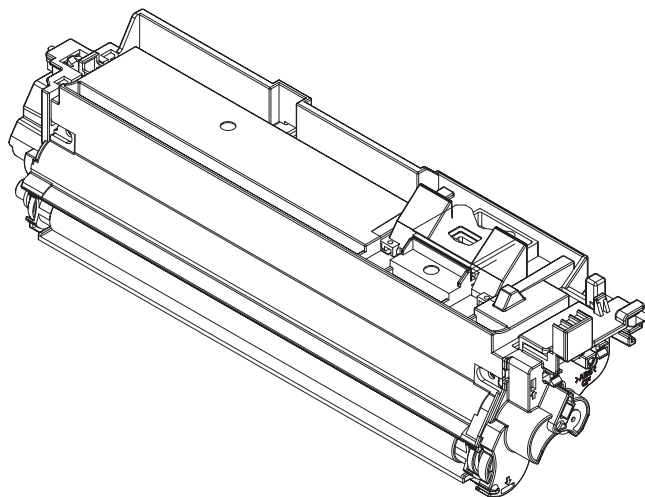

List 8 - Developer Unit (08-)

Ref. No.	Part Code	Description	Applicable Model	SP	120V	230V	Remarks
08	2D993050	DV-500K DLP UNIT K		X	-	1	
08	2D993260	DV-502K DLP UNIT K		X	1	-	
08	2D993060	DV-500Y DLP UNIT Y		X	-	1	
08	2D993270	DV-502Y DLP UNIT Y		X	1	-	
08	2D993070	DV-500M DLP UNIT M		X	-	1	
08	2D993280	DV-502M DLP UNIT M		X	1	-	
08	2D993080	DV-500C DLP UNIT C		X	-	1	
08	2D993290	DV-502C DLP UNIT C		X	1	-	

9. Frame MP Assembly (9-)

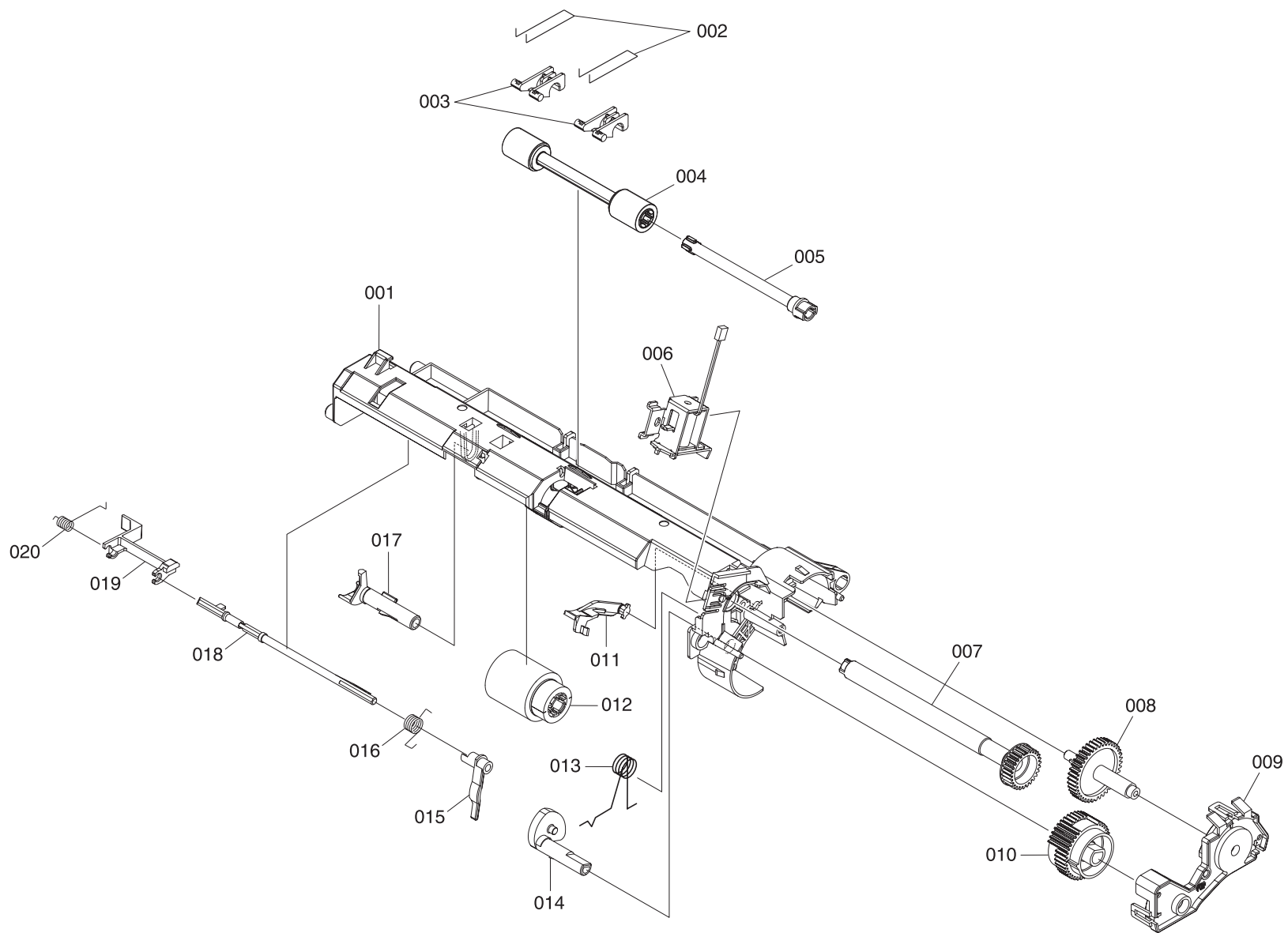

List 9 - Frame MP Assembly (9-)

Ref. No.	Part Code	Description	Applicable Model	SP	120V	230V	Remarks
	2D968390	FRAME MP ASSY		X	1	1	
09-001	+ 5MVX866CH001	FRAME M/P		-	1	1	
09-002	+ 5MMW601SD001	SPRING MID M/P		-	2	2	
09-003	+ 5MVX321DN014	BUSH MID M/P		X	2	2	
09-004	+ 5AAVR0LL+050	ROLL MID M/P ASSY		X	1	1	
09-005	+ 5MVT676CB003	SHAFT MID B		-	1	1	
09-006	+ WSAA0160	SOLENOID M/P ASSY		X	1	1	
09-007	+ 5MVG133DN008	GEAR M/P Z27		X	1	1	
09-008	+ 2D916010	GEAR MID Z42S		-	1	1	
09-009	+ 5MVX662DN003	HOLDER CLUTCH M/P		-	1	1	
09-010	+ 5MVG148DN063	GEAR M/P Z40		-	1	1	
09-011	+ 5MVX522DN004	LEVER CAM		-	1	1	
09-012	+ 5AAVR0LL+051	ROLLER M/P ASSY		X	1	1	
09-013	+ 5MMW161LD043	SPRING CAM M/P		-	1	1	
09-014	+ 5MVX433DN002	CAM M/P		X	1	1	
09-015	+ 5MVX421SB021	ACTUATOR M/P C		-	1	1	
09-016	+ 5MMW161SD009	SP ACTUATOR M/P C		X	1	1	
09-017	+ 5MVX422DN007	HOLDER FEED M/P		X	1	1	
09-018	+ 5MVT754SB001	ACTUATOR M/P A		-	1	1	
09-019	+ 5MVX621SB010	ACTUATOR M/P B		-	1	1	
09-020	+ 5MMW161SD010	SP ACTUATOR M/P B		-	1	1	

10. MP Tray (10-)

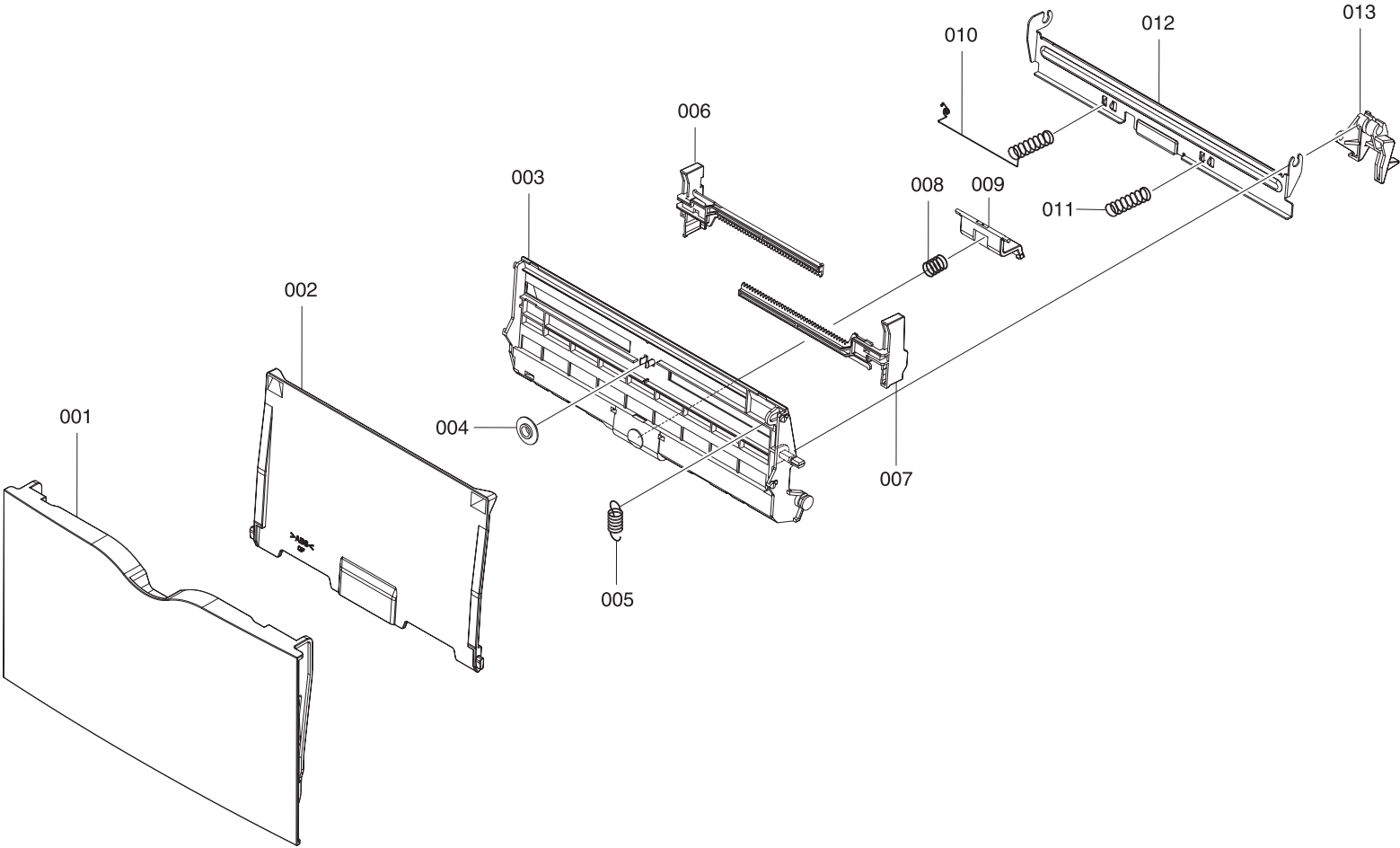

List 10 - MP Tray (10-)

Ref. No.	Part Code	Description	Applicable Model	SP	120V	230V	Remarks
	2D969170	TRAY M/P ASSY		X	1	1	
10-001	+ 2D906020	COVER M/P		X	1	1	
10-002	+ 2D906010	TRAY M/P		-	1	1	
10-003	+ 5MVB864SH009	BASE M/P		-	1	1	
10-004	+ 5MVG127DH001	GEAR MANUAL		-	1	1	
10-005	+ 5MMW261SM001	SPRING LOCK M/P		-	1	1	
10-006	+ 2D906030	GUIDE M/P L		-	1	1	
10-007	+ 2D906040	GUIDE M/P R		-	1	1	
10-008	+ 5MMW261LD039	SPRING SEPARATOR		-	1	1	
10-009	+ 5AAVCASET248	SEPARATOR M/P ASSY		X	1	1	
10-010	+ 2D916020	SP BOTTOM M/P L		-	1	1	
10-011	+ 5MMW461SD004	SP BOTTOM M/P R		-	1	1	
10-012	+ 5AAVCASET249	BOTTOM MULTI ASSY		X	1	1	
10-013	+ 5MVX533DN002	BRACKET BOTTOM		-	1	1	

11. Primary Transfer Unit (11-)

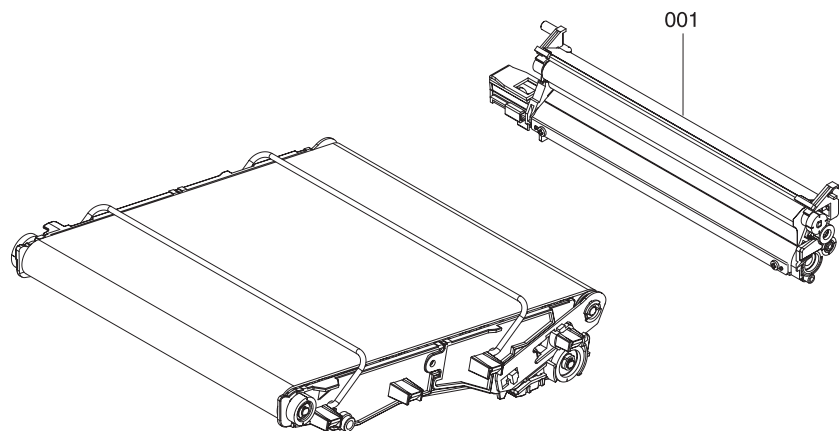

List 11 - Primary Transfer Unit (11-)

Ref. No.	Part Code	Description	Applicable Model	SP	120V	230V	Remarks
	2D993130	TR-500 PRE TRANSFER UNIT		X	1	1	
11-001	+ 2D993250	CLEANING UNIT		X	1	1	

12. Paper Cassette (12-)

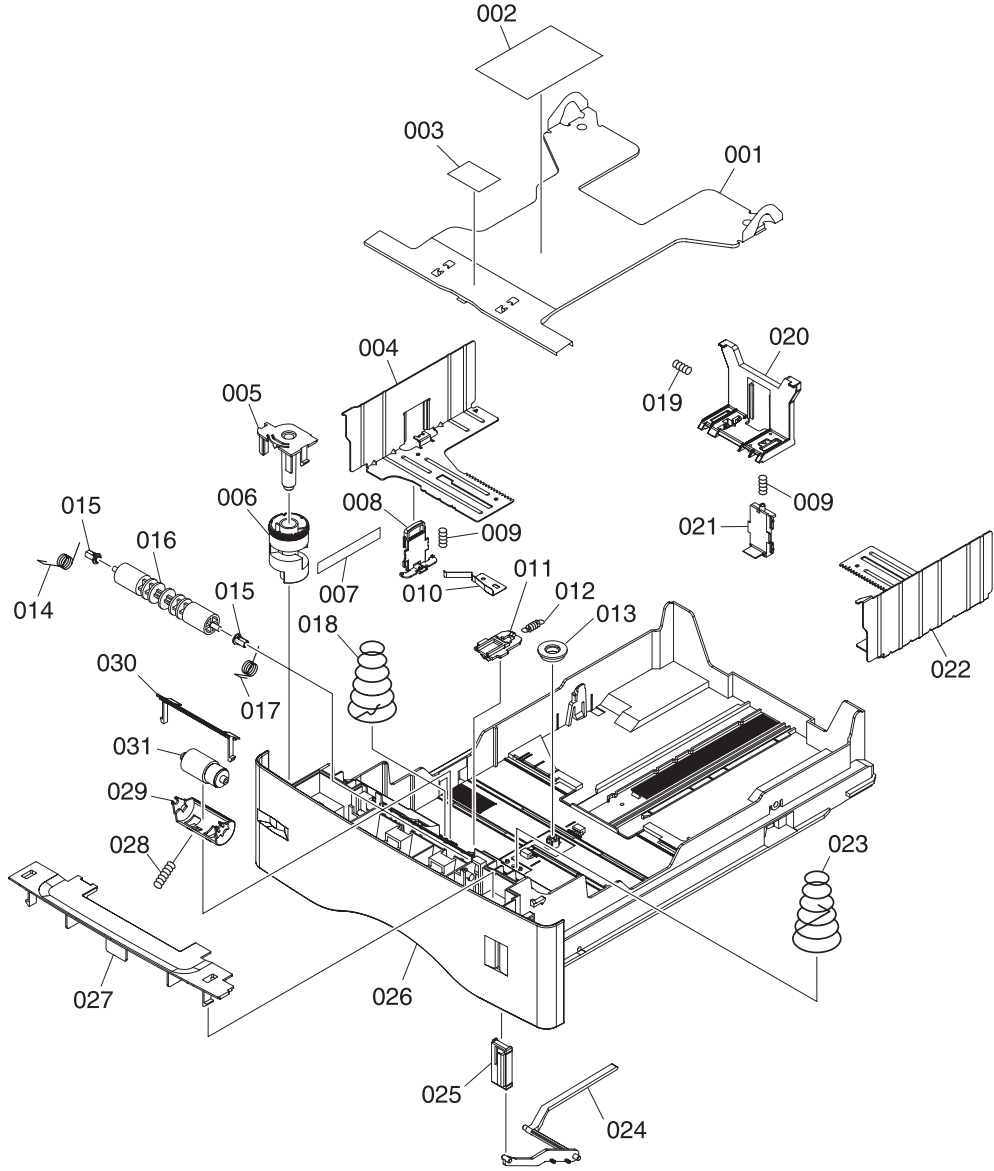

List 12 - Paper Cassette (12-)

Ref. No.	Part Code	Description	Applicable Model	SP	120V	230V	Remarks
	5PLPXZ7APKX	PC-60LG(A4) CASSETTE ASSY		X	-	1	
	5PLPXCUIAPKX	PC-60LG(LTR) CASSETTE ASSY	Excl.KMTW	X	1	-	
	5PLPXDSAPKX	PC-60LG(A4) CASSETTE ASSY	KMTW only	X	1	-	
12-001	+ 5MMX883SD004	PLATE BOTTOM		-	1	1	
12-002	+ 5MVVL221GE1H	LABEL OPERATION	Excl.KMTW	-	1	1	
12-002	+ 5MVVL221GE1J	LABEL OPERATION J	KMTW only	-	1	1	
12-003	+ 5MVS421RN004	SHEET FRICTION		X	1	1	
12-004	+ 5MML877SN002	PLATE SIDE L		-	1	1	
12-005	+ 5MVX543DH002	HOLDER DIAL		-	1	1	
12-006	+ 5MVM586SH001	DIAL CASSETTE		-	1	1	
12-007	+ 5MVVL171WN03	LABEL SIZE LGL		-	1	1	
12-008	+ 5MVX642DG001	LOCK LEVER SIDE		-	1	1	
12-009	+ 5MMW166LD010	SPRING LOCK GUIDE		-	2	2	
12-010	+ 5MMX653LD004	EARTH PLATE		-	1	1	
12-011	+ 5MVX432DN005	LOCK BOTTOM		X	1	1	
12-012	+ 5MMW251LD048	SP STOPPER BOTTOM		-	1	1	
12-013	+ 5MVG127DB046	GEAR CASSETTE		-	1	1	
12-014	+ 5MMW161LD045	SPRING FEED L		-	1	1	
12-015	+ 5MVM164DN007	BUSH4		X	2	2	
12-016	+ 5MVT774DN001	ROLLER FEED		X	1	1	
12-017	+ 5MMW161LD044	SPRING FEED R		-	1	1	
12-018	+ 5MMW682LD005	SPRING BOTTOM EARTH	Excl.KMTW	-	1	1	
12-018	+ 5MMW682LD007	SPRING BOTTOM EARTH	KMTW only	-	1	-	
12-019	+ 5MMW151SD003	SPRING END		-	1	1	
12-020	+ 5MVX664DN001	END FENCE		-	1	1	
12-021	+ 5MVX642DG002	LOCK LEVER END		-	1	1	
12-022	+ 5MML877SN001	PLATE SIDE R		-	1	1	
12-023	+ 5MMW682LD004	SPRING BOTTOM	Excl.KMTW	-	1	1	
12-023	+ 5MMW682LD006	SPRING BOTTOM	KMTW only	-	1	-	
12-024	+ 5MVX764DN001	LEVER INDICATOR		X	1	1	
12-025	+ 5MVX422SD002	INDICATER PAPER		-	1	1	
12-026	+ 5MVB987SH018	BASE CASSETTE LGL		-	1	1	
12-027	+ 5MVX853SH003	COVER ROLLER		-	1	1	
12-028	+ 5MMW151LD004	SPRING RETARD		-	1	1	
12-029	+ 5MVX644DN001	HOLDER RETARD		-	1	1	
12-030	+ 5MVX632SH005	GUIDE RETARD		-	1	1	
12-031	+ 5AAVR0LL+052	RETARD ROLL ASSY		X	1	1	

13. Accessories (A-)

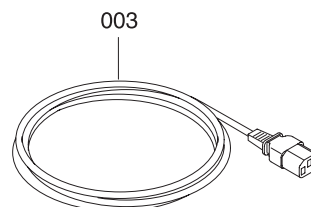
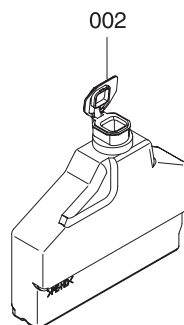
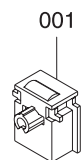

List 13 - Accessories (A-)

Ref. No.	Part Code	Description	Applicable Model	SP	120V	230V	Remarks
13-001	5AAYTK20**03	GRID CLEANER 3 ASSY		X	1	1	
13-002	2D993240	BOTTLE ASSY		X	2	2	
13-003	2BM27920	AC CORD ASSY	Excl. KMUK/KMAUS	-	-	1	
13-003	2A829210	AC CORD ASSY	KMUK	-	-	1	
13-003	2A829190	AC CORD ASSY	KMAUS	-	-	1	
13-003	2BM27910	AC CORD ASSY		-	1	-	

14. Packing Assemblies (P-)

Ref. No.	Part Code	Description	Applicable Model	SP	120V	230V	Remarks
P-001	2D977010	PACKING ASSY		X	-	1	
P-001	2D977020	PACKING ASSY		X	1	-	
P-002	2D980150	POLY BAG		X	1	1	